

- WATERPROOF SLIP RING DESIGN
- QUICK RELEASE CRANK ARM
- DURABLE CONSTRUCTION
- BALL BEARING SLIP RING

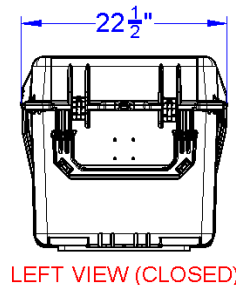
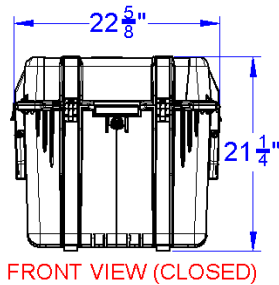
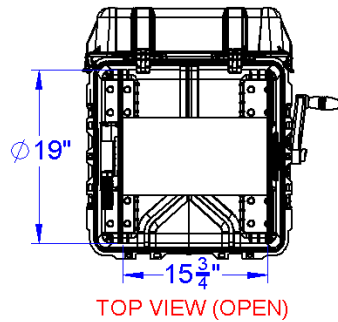

OVERALL SPECIFICATIONS:

Width.....	22.5 in. (57 cm)
Length.....	22.5 in. (57 cm)
Height (without wheels).....	21.2 in. (54 cm)
Weight (without cable).....	42.5 lbs. (19.3 kg)

REEL DIMENSIONS:

Traverse Length.....	15.9 in. (40.4 cm)
Fill Diameter.....	19.0 in. (48 cm)
Barrel Diameter.....	8.4 in. (21.3 cm)

DIVE CABLE (C-2300C):

Cable Diameter.....	0.38 in. (9.7 mm)
Total Length Capacity.....	~2039 ft. (621.5 m)
Cable Weight.....	~155 lbs. (70.5 kg)
Total Weight.....	~198 lbs. (90 kg)

ROV CABLE (C-3400):

Cable Diameter.....	0.55 in. (14 mm)
Total Length Capacity.....	~962 ft. (293.2 m)
Cable Weight.....	~96 lbs. (44 kg)
Total Weight.....	~139 lbs. (63 kg)

OPTIONS:

1. Customer Specified Connector
2. Case Wheels