

- UNDERWATER GRINDER
- BRUSHLESS 3 PHASE FLOODED MOTOR
- NO SHAFT SEALS
- REPLACEABLE MOTOR
- STANDARD 1/4 SHAFT COLLAR
- BI-DIRECTIONAL MOTOR

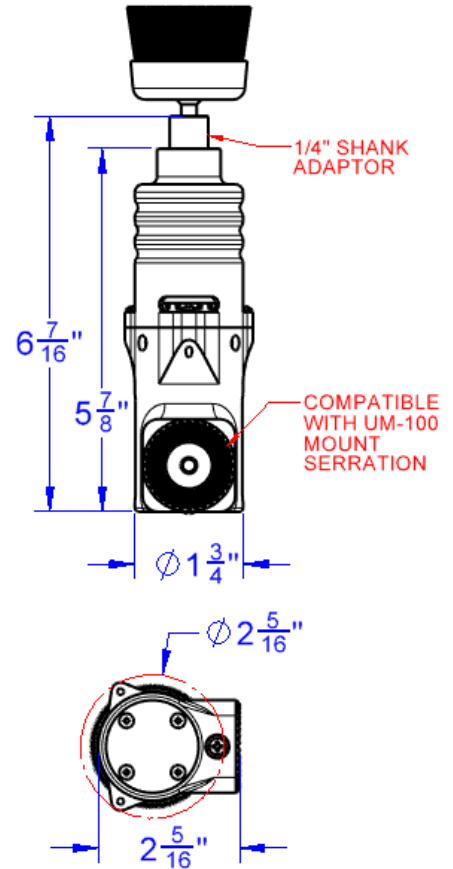

## APPLICATIONS INCLUDE: UNDERWATER VEHICLE

### MECHANICAL:

Diameter..... 1.75 in. (44.5 mm)  
 Length..... 6.438in. (163.5 mm)  
 Weight in air..... 1.0 lb. (0.45 kg)  
 Weight in seawater..... 0.5 lb. (0.23 kg)  
 Rotation Speed (Unloaded)..... 2,000 rpm  
 Depth Rating..... 2,000 ft. (610 m)  
 Housing Material..... Delrin

### ELECTRICAL:

Input Voltage..... 12-20 VDC  
 Power..... 400 Watts  
 Free Running Amperage..... 15A  
 Loaded Amperage..... 20A

### MOTOR CONTROL:

12-20V 30A+ ESC recommended. PWM signal should be limited to achieve a max of 400W (20A@20V). Exceeding 20A will damage the motor.

### CONNECTOR:

Standard Connector..... MCIL3M

1. ESC wire 1
2. ESC wire 2
3. ESC wire 3

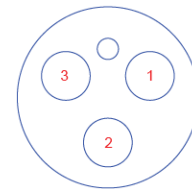

Mate for Connector..... MCBH3F

### OPTIONS:

1. 30A ESC
2. MCBH3
3. UM-100 Mount