

- UNDERWATER GRINDER
- BRUSHLESS 3 PHASE FLOODED MOTOR
- NO SHAFT SEALS
- REPLACEABLE MOTOR
- STANDARD 5/8 ARBOR
- BI-DIRECTIONAL MOTOR

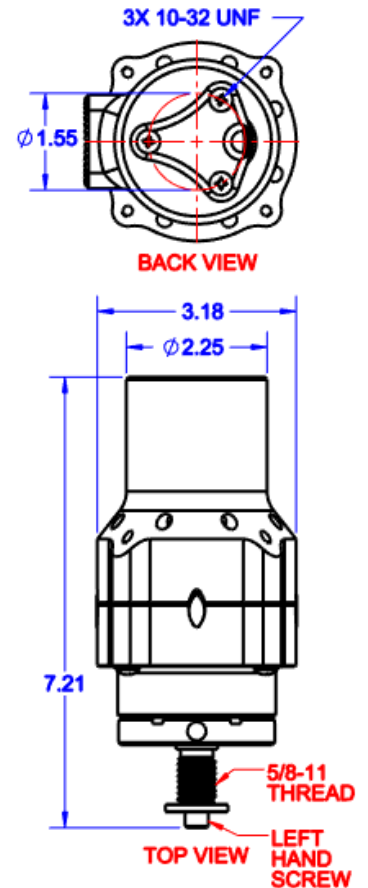

APPLICATIONS INCLUDE: UNDERWATER VEHICLE

MECHANICAL:

Diameter.....	2.25 in. (56 mm)
Length.....	7.2 in. (183 mm)
Weight in air.....	2.9 lb. (1.32 kg)
Weight in seawater.....	2.0 lb. (0.91 kg)
Wrist Rotation Speed (Unloaded).....	2,000 rpm
Depth Rating.....	2,000 ft. (610 m)
Housing Material.....	Stainless Steel & Delrin

ELECTRICAL:

Input Voltage.....	12-24 VDC
Power.....	500 Watts
Free Running Amperage.....	20A
Loaded Amperage.....	30A

MOTOR CONTROL:

12-24V 50A+ ESC recommended. PWM signal should be limited to achieve a max of 500W or 20A. Exceeding 30A will damage the motor.

CONNECTOR:

Standard Connector.....MCIL3M

1. ESC wire 1
2. ESC wire 2
3. ESC wire 3

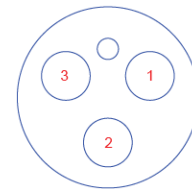

Mate for Connector.....MCBH3F(12Ga)

OPTIONS:

1. 50A ESC (Limit to 50% PWM)
2. MCBH3 (High Current) Connector
3. 4in Nylon Cup Brush, Red
4. [MPM-101](#) Mount
5. [UM-100](#) Mount